

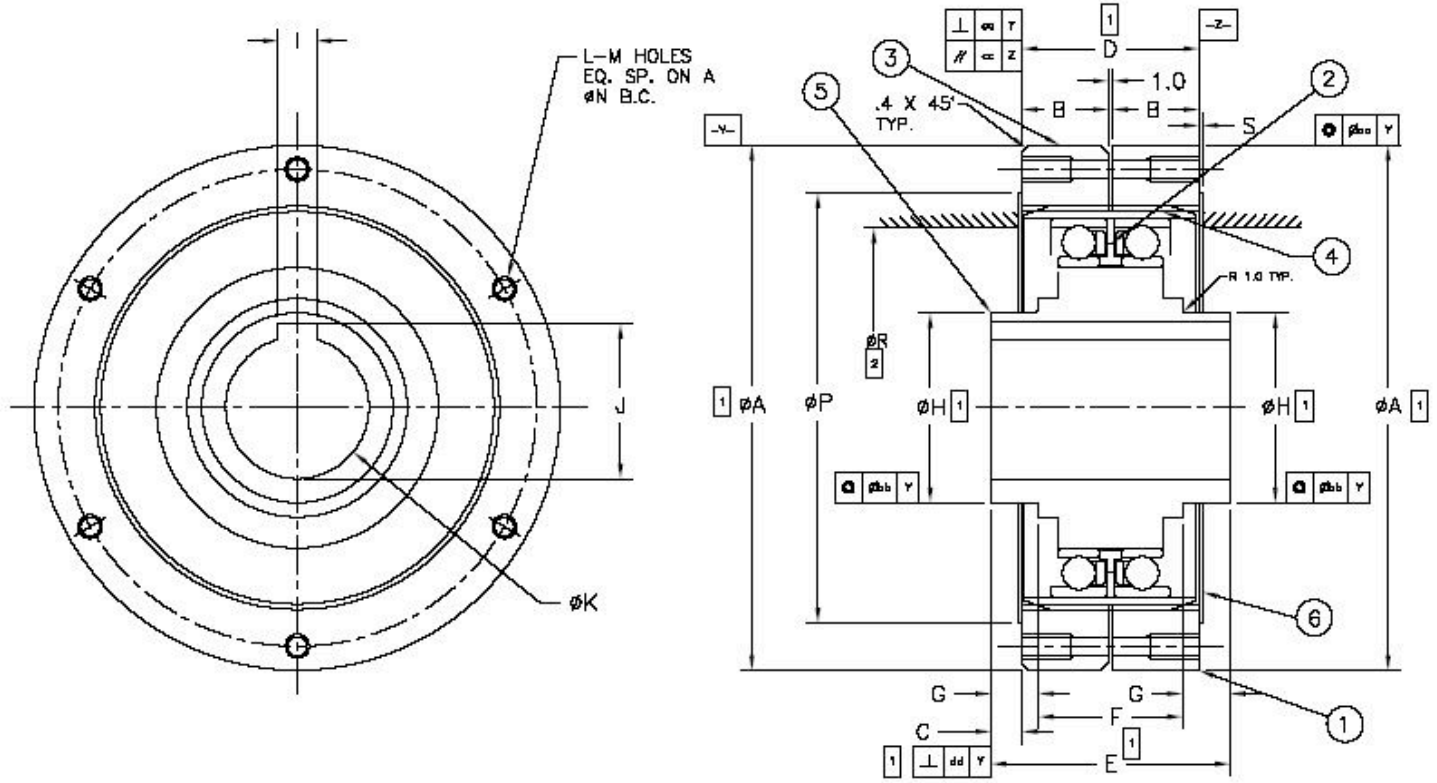

N-HDA-M1 Installation Drawing



- 1 DIMENSIONS DENOTE MAXIMUM EXTENT OF ENCROACHMENT OF ADJOINING STRUCTURE.
- 2 DIMENSIONS ESTABLISH INTERFACE AND INSTALLATION REQUIREMENTS. MAINTAIN AT ASSEMBLY AND UNDER ALL OPERATING LOAD CONDITIONS.
- 3 USE ALLOY STEEL SCREWS TORQUE TO MANUFACTURES MAXIMUM RECOMMENDED VALUE. USE LOCTITE OR OTHER MEANS TO PREVENT LOOSENING.
- 4. MAINTAINING STANDARD COMPONENTS IN "AS RECEIVED" SETS IS RECOMMENDED.
- 5. DRAWING IS FOR DIMENSIONAL REVIEW ONLY.
DO NOT SCALE



Dimensions: Millimeters

	20	25	32	40	50	65
ØA	70 -0.10 -0.040	85 -0.12 -0.047	110 -0.12 -0.047	135 -0.14 -0.054	170 -0.14 -0.054	215 -0.15 -0.061
B	12	14	18	21	26	35
C	6.5	5.5	6.5	12.5	12.5	8
D	25	29	37	43	53	71
E	38	40	50	68	78	87
F	21.5	25	30	44	54	59
G	8.25	7.5	10	12	12	14
ØH	20 +0.009 -0.004	30 +0.009 -0.004	40 +0.011 -0.005	50 +0.011 -0.005	60 +0.012 -0.007	70 +0.012 -0.007
I	4 ± .015	6 ± .015	8 ± .018	10 ± .018	12 ± .0215	14 ± .0215
J	13.8	22.8	33.3	38.3	43.3	53.8
ØK	12 +0.018 -0	20 +0.021 -0	30 +0.021 -0	35 +0.025 -0	40 +0.025 -0	50 +0.025 -0
L	6	6	6	6	6	6
M	M3 x 6 DP	M4 x 8 DP	M5 x 10 DP	M6 x 12 DP	M8 x 16 DP	M10 x 20 DP
ØN	60	75	100	120	150	195
ØP	54 ± .5	69.4 ± .5	92 ± .5	111 ± .5	134.4 ± .5	176 ± .5
ØR	47	59	77	95	119	150
S	.8	.8	.8	1.6	1.6	1.6
aa	.016	.016	.017	.019	.024	.027
bb	.013	.016	.016	.017	.021	.025
cc	.017	.024	.026	.026	.028	.034
dd	.010	.012	.012	.012	.015	.015
Weight kg (lb)	.6 (1.3)	1 (2.2)	2 (4.4)	3.6 (7.9)	7.2 (16)	14 (31)

Contact NAC Drive Systems For Certified Engineering Drawings.



Size	Maximum Input Speed		Ratio	Input Speed 3000 rpm			Input Speed 1500 rpm			Input Speed 1000 rpm		
				Output Torque	Output Speed	Input Power	Output Torque	Output Speed	Input Power	Output Torque	Output Speed	Input Power
	Grease	Oil		N.m	rpm	kw	N.m	rpm	kw	N.m	rpm	kw
20	3500	5000	80	25	37.5	0.123	25	18.8	0.059	25	12.5	0.039
			84	25	35.7	0.117	25	17.9	0.056	25	11.9	0.037
			100	30	30	0.118	33	15	0.062	33.6	10	0.041
			120	30	25	0.101	37.5	25	0.060	33.6	25	0.042
			126	30	24	0.097	37.5	12	0.058	43.5	8	0.044
25	3000	5000	80	40	37.5	0.197	40	18.8	0.094	40	12.5	0.062
			100	50	30	0.197	55	15	0.104	56	10	0.069
			120	50	25	0.169	62.5	12.5	0.101	72.5	8.3	0.074
			150	50	20	0.146	62.5	10	0.085	72.5	6.7	0.062
			160	50	18.8	0.139	62.5	9.4	0.078	72.5	6.3	0.057
32	3000	4500	80	100	37.5	0.493	100	18.8	0.235	100	12.5	0.153
			100	120	30	0.473	132	15	0.248	135	10	0.165
			135	120	22.2	0.363	150	11.2	0.215	175	7.5	0.163
			160	120	18.8	0.312	150	9.4	0.185	175	6.3	0.140
			200	120	15	0.264	150	7.5	0.156	175	5	0.118
40	3000	4500	80	200	37.5	0.986	200	18.8	0.469	200	12.5	0.305
			84	200	35.7	0.939	200	17.9	0.447	200	11.9	0.291
			100	240	30	0.947	265	15	0.497	270	10	0.330
			125	240	24	0.777	300	12	0.462	300	8	0.300
			160	240	18.8	0.624	300	9.4	0.370	300	6.3	0.240
			168	240	17.9	0.594	300	8.9	0.352	300	6	0.228
			200	240	15	0.527	300	7.5	0.312	300	5	0.202
50	2500	3500	80	360	37.5	1.775	360	18.8	0.844	360	12.5	0.549
			100	450	30	1.775	495	15	0.929	505	10	0.617
			120	450	25	1.518	550	12.5	0.881	600	8.3	0.625
			150	450	20	1.25	550	10	0.723	600	6.7	0.513
			160	450	18.8	1.169	550	9.4	0.678	600	6.3	0.481
			200	450	15	0.989	550	7.5	0.572	600	5	0.405
65	1750	1750	80				800	18.8	1.876	800	12.5	1.221
			96				900	15.6	1.760	1015	10.4	1.335
			100				900	15	1.689	1015	10	1.282
			126				1000	11.9	1.558	1150	7.9	1.162
			132				1000	11.4	1.487	1150	7.6	1.110
			135				1000	11.2	1.454	1150	7.4	1.086
			160				1000	9.4	1.233	1150	6.3	0.921
			200				1000	7.5	1.040	1150	5	0.776
			80	1500	1500	80				1500	18.8	3.518
100							1800	15	3.377	2000	10	2.442
125							2000	12	3.077	2300	8	2.301
168							2000	8.9	2.348	2300	6	1.755
200							2000	8.9	2.079	2300	5	1.552
250							2000	6	1.758	2300	4	1.311

Note: Output Torque ratings are based on an L-10 life of 5000 hours.